



**УДК 624.012.035**

**STRENGTHENING AND CALCULATION ANALYSIS OF BENDING  
REINFORCED CONCRETE ELEMENTS**

**АНАЛІЗ СТАНУ ПІДСИЛЕННЯ ТА РОЗРАХУНКУ ЗГИНАЛЬНИХ  
ЗАЛІЗОБЕТОННИХ ЕЛЕМЕНТІВ**

**Borisyuk A.P., candidate of engineering sciences, associate professor, Ziatyuk Y.Y., senior lecturer, Lysyuk M.O., student, Yevtushenko V S student, (National university of water and environmental engineering, Rivne).**

**Борисюк О.П., к.т.н., проф., Зятюк Ю.Ю., ст. викладач, Лисюк М.О. студент, Євтушенко В.С. студент, (Національний університет водного господарства та природокористування м. Рівне).**

Аналіз методів підсилення залізобетонних конструкцій показав, що підсилювати конструкції, які працюють на згин, можна як способом нарощування поперечного перерізу, так і способом зміни розрахункової схеми роботи конструкції. На сьогоднішній день не повністю досліджений вплив малоциклових навантажень високих рівнів на роботу підсилених згинальних залізобетонних елементів. Використання сучасних вуглепластикових матеріалів та сталевібробетону є ефективним способом підсилення згинальних залізобетонних елементів. Розробка такого методу підсилення та удосконалення алгоритму розрахунку є вельми актуальним, оскільки порівняння теоретичних досліджень з результатами експерименту дасть можливість підтвердити достовірність теоретичних висновків і передумов, покладених в їх основу, а також заговорити про застосування їх на практиці

During the operation of constructions, buildings and structures, as a result of the influence of various factors, indicators of the technical condition, which causes the need for reinforcement, is reduced. It may also occur due to the end of the project term of its operation, changes in the calculation scheme of an element, due to damage and operation in a disabling or emergency condition, errors in designing, erection, use of substandard materials, and poor performance of works, negative effects of the environment, etc.

During the experiment to increase the bearing capacity of the test beams, it is possible to argue about the effectiveness of this simultaneous enhancement of compressed and stretched zones.

Національний університет  
The analysis of methods of strengthening reinforced concrete structures showed, that strengthen structures that work for bending can be both a way of increasing the cross-section, and a way to change the calculation scheme of the work of structure. To date, the effect of low-cycle loads of high levels on the work of strengthened bending reinforced concrete elements is not fully investigated. Research in this area is relevant and necessary for modern construction. The use of modern carbon-plastic materials and steel-fiber reinforced concrete is an effective way to strengthen bending reinforced concrete elements.

The development of such a method to enhance and improve the algorithm of calculation is very relevant, whereas comparing theoretical research with the results of the experiment will prove the reliability of the theoretical conclusions and prerequisites that were laid down in their basis, as well as talk about their application in practice.

**Ключові слова :**

Підсилення, навантаження, балка, сталевіфібробетон, композити.  
Strengthen, load, beam, steelfiberconcrete, composites.

**Introduction.** During the operation of constructions, buildings and structures, as a result of the influence of various factors, indicators of the technical condition, which causes the need for reinforcement, is reduced. It may also occur due to the end of the project term of its operation, changes in the calculation scheme of an element, due to damage and operation in a disabling or emergency condition, errors in designing, erection, use of substandard materials, and poor performance of works, negative effects of the environment, etc.

The most common defects that arise during the exploitation of reinforced concrete structures are the following: excessive structural deformations, excessive crack widths in stretched zones of structures, destruction of the protective layer with the buckling of the fittings and the coating of the last corrosion, violation of the solidity of the structures (shells, chipping, holes, stratification, etc.) , wetting and icing of the surfaces of structures, salting and flaking surfaces of concrete structure.

Strengthening of reinforced concrete structures is carried out only when all other possibilities of ensuring their reliable exploitation are exhausted. Namely: reduction of technological load, introduction of temporary unloading supports during mounting and dismantling equipment, simultaneous loading of temporary loads of large areas of overlaps of multistory buildings, reduction of vibration levels, and etc.

**Status questions and research tasks.** The analysis of methods of strengthening of reinforced concrete structures showed that reinforce structures that work on bending is possible by the way of increasing the cross-section and the way of change the design scheme of the construction.



Their works have been devoted to the study of strengthening bending reinforced concrete elements: B.A. Ashimov, A.B. Barashikov, Y.M. Blali, Z. Y.Bliharsky, O.P. Borisyuk, B.A. Boyarchuk, O.I. Valovoj, I.O. Valovoj, A.P. Vasilev, O.V. Wojcechowski, E.O. Grinevich, S.S. Davydov, V.S. Dovbenko, I.V. Zadorozhnikova, A. Kasasbeh, V.G. Kvasha, O.P. Kononchuk, M.I. Kisilier, M.D. Klimpush, O.P. Krichevsky, S.O. Krichevsky, A.I. Malganov, I.V. Melnik, S.V. Melnik, L.A. Murashko, A.Y. Murin, S.M. Novikova, F.N. Rabinovich, Y.V. Rimar, A.K. Saleh, M.Y. Smolyaninov, S.D. Semenyuk, O.P. Sunak, P.O. Sunak, G.K. Haydukov, O.L. Shagin and others.

M.O. Valovoj in his work [1] investigated the effect of low-cycle repeated loads on the crack resistance and deformability of reinforced concrete beams amplified in a compressed zone by a layer of concrete. The author concludes that repeated low-cycle loads of high levels can lead to excess crack widths and deflections of corresponding permissible values set by normative documents.

M.Y. Smolyaninov [2] conducted a study of strength improvement and crack resistance of reinforced concrete beams of rectangular and tambourine sections, reinforced with acrylic polymer solution by the action of short-term static and frequently repeated loads.

V.S. Dovbenko [3] completed the study of the work of reinforced concrete beams reinforced with a polymeric composition "Silur" with repeated low-cycle loads. The performed studies have shown that the polymer composition increases the strength, crack resistance and stiffness of reinforced concrete beams at single load and in repeated low-cyclic loads. The increase of bearing capacity of reinforced concrete beams, by the polymer composition, was 10%.

V.G. Kvasha, I.V. Melnyk and M.D. Klimpush [4, 5] conducted experimental and theoretical studies of the stress-strain state, strength, crack resistance and deformation of reinforced concrete beams reinforced by carbon-plastic composites at static and frequently repeated loads.

In the work of M.I. Kisiliera [6] presents the study of bending reinforced concrete elements, with sheet reinforcement glued by epoxy glue in the stretched zone. Three schemes of destruction of glued beams were revealed: the separation of the protective layer of concrete in the stretched zone, biasing on glue connection, the flow of the external stretched armature.

In the work of B.A. Boyarchuk [7] carried out experimental research of bending reinforced concrete elements reinforced by the expansion of the stretched zone by layers of Steel Fiber Reinforced Concrete, polymer concrete and heavy concrete. The author proposes the development of methods for calculating reinforced concrete bending elements reinforced by the extension of the stretched zone with different materials in normal sections.

S.D. Semenyuk and Y.G. Boloshenko in their works [8] investigated the effectiveness of strengthening the compressed zone of bending reinforced concrete elements under the influence of low-cycle loads. The authors concluded that the use of Steel Fiber Reinforced Concrete as an alternative material for strengthening

the compressed zone of reinforced concrete beams is a promising direction in connection with its advantages compared to traditional fine-grained concrete.

A.Y. Barashnikov and I.V. Zadorozhnikova [9] proposed a method for calculating the reinforced concrete elements according to the deformation model. As the calculation is proposed to take a section, the deformation of which is equal to the average deformation in the area between cracks. Simplified concrete deformation diagrams have been used.

Steel Fiber Reinforced Concrete, fine-grained concrete and 3% wires fiber from waste ropes of the brand LK-0,6x19 were used to reinforce beams in works [9] of I.V. Zadorozhnikova. According to the results obtained after the experiment, the bearing capacity of all reinforced experimental samples increased to 1.1 ... 1.3 times. The greatest growth of bearing capacity, within the limits of 24 ... 26%, was found in beams reinforced with a layer of polymer concrete, and the least increase in bearing capacity - 13 ... 17% when it reinforced with reinforced fine-grained concrete. The condition of the strength of a complex normal section with reinforcement of Steel Fiber Reinforced Concrete in a compressed zone is written as follows:

$$M \leq R_b b x [h - 0.5x] + R_{SFB} \delta d b [h_0 + 0.5\delta] \quad (1)$$

Y.V. Rimar explored reinforced concrete beams to reinforce and reinforce by increasing intersection fittings under load in a stretched zone. The effect of reinforce is the higher when there are the less stress is in the working armature at the moment of amplification [10].

Quite interesting is the study of French and Tunisian scientists O. Ben Mekki, D. Siegert [11] and others. The authors have developed a rational design of the span structure of small bridges using modern high-performance materials. In developing the design of bridges with a span of 10,5m were used wooden beams with plates coated with Steel Fiber Reinforced Concretes in a stretched zone, and reinforced by carbon drawers in the stretched zone. As the results of experimental studies have shown, the design has confirmed sufficient resistance to static and repeated loads. As a result of the test, the limiting vibration parameters for SLS are set. The authors created light span structures of small bridges, which can be erected without the use of heavy construction equipment.

Experiments of the strengthening of reinforced concrete structures that have been conducted in Europe, are summarized in the technical report fib [12]. This document contains basic requirements, provisions for the design, calculation and reinforcement work. On the basis of different fibers: carbon, aramid and glass, the report shows graphs of deformation of composites, as well as reliability ratios for these materials

A.A. Shylin [13] developed recommendations for the strengthening of reinforced concrete structures with composite materials. He described the bases of designing and technology of external strengthening of reinforced concrete constructions by modern composite materials based on carbon, aramid and fiber glass. Here are the main provisions for the design of reinforced concrete structures

in the 1 st and 2 nd group of boundary states. The technology of strengthening by composite materials of the new generation is presented. The questions of quality of performed works, requirements to raw materials and conditions of work on strengthening, and also requirements on obligatory monitoring of the reinforced construction are considered. The experience of JSC "Triada - Holding" of strengthening has been analyzed.

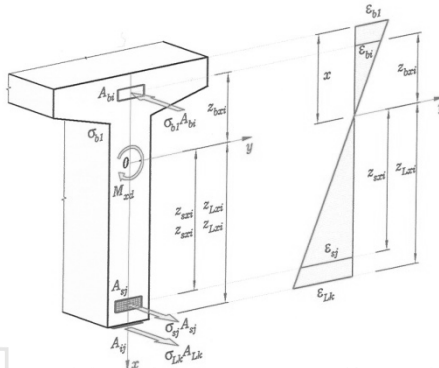

Fig. 2. The calculation scheme of the normal section of reinforced concrete bending element reinforced with glued strips

I.V. Melnik and A.Y. Murin [14] conducted a theoretical and experimental study of the influence of strengthening parameters on the strength, deformability and crack resistance of the beam elements. The optimum percentage of strengthening of reinforced concrete beams reinforced by external composite fitting was searched.

The peculiarity of the proposed theory is the reduction of the number of external composite fitting by strength, deformability and cross-sectional area to the corresponding amount of internal steel fittings.

$$A_{s,red} = A_s + A_f \frac{R_{fy}}{R_s}, \quad (2)$$

Borisyuk O.P. and Kononchuk O. P.[15] improved the method of calculation of bearing capacity of normal sections of bending reinforced concrete elements, reinforced by composite materials for the effects on them of single and low cycle loads in which an adapted calculation of the required cross-sectional area of the external composite armature of reinforcement was developed complying with the requirements of DBN V.2.6.-98: 2009 and DSTU B.V.2.6-156: 2010. It is possible to calculate the cross-sectional area of the reduced working armature in the case of short-term re-load, then the formulas have the form:



$$A_{s2,red(1)} = \frac{f_{cd,cyc} b z_{cyc(1)} \sum_{k=1}^5 \frac{a_{k,cyc}}{k+1} \left( \frac{\varepsilon_{cu1,cyc}}{\varepsilon_{c1,cyc}} \right)^k + A_{s1} E_s \varepsilon_{s1(1)}}{\varepsilon_{s2,red(1)} \alpha_f E_s} ;(3)$$

$$M_{S,cyc(1)} = f_{cd,cyc} d z_{cyc(1)}^2 \sum_{k=1}^5 \frac{a_{k,cyc}}{k+2} \left( \frac{\varepsilon_{cu1,cyc}}{\varepsilon_{c1,cyc}} \right)^k + A_{s1} E_s \frac{\varepsilon_{cu1,cyc}}{z_{cyc(1)}} (z_{cyc(1)} - a_1)^2 + A_{s2,red} \alpha_f E_s \frac{\varepsilon_{cu1,cyc}}{z_{cyc(1)}} (d - z_{cyc(1)})^2 ;(4)$$

Borisyuk O.P. and Ziatyuk Y.Y in the articles [16, 17] describes the experimental research of the amplification layers of reinforced concrete beams with glued composites in the form of carbon fibers in the stretched zone, and steelfiberconcrete in the compressed zone. You can confirm about the effectiveness of this simultaneous amplification of compressed and stretched zones by increasing the bearing capacity of the experimental beams.

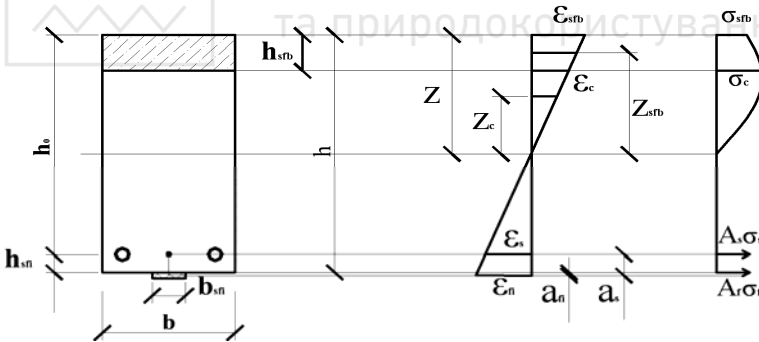

Fig.3. Stress - strain state of the rectangular section with strengthening

For such a cross-section, the equilibrium condition has the form:

$$M_{Ed} \leq M_{Ss(1)} = M_{c(1)} + M_{s(1)} + M_{sfb} ; (5)$$

$$S_{c(1)} = S_{s1(1)} + S_{f1(1)} - S_{sfb} ; (6)$$



where  $M_{Ed}$ ,  $M_{Ss(1)}$ ,  $M_{c(1)} + M_{s(1)}$  - calculated values relevant external bending moment, moment of internal efforts, efforts in compressed concrete and armature at the value of  $\epsilon_c = \epsilon_{c(1)}$ ;

$S_{c(1)}$ ,  $S_{s(1)}$ ,  $S_{f(1)}$  - internal efforts relevant in compressed concrete and armature are  $A_{s1}$  and  $A_f$ .

$$M_{c(1)} = b \int_{h-z(1)}^{z(1)-h_{sf}} \sigma_c z dz = b \left[ \frac{z(1)}{\epsilon_{c(1)}} \right]^2 \int_0^{\epsilon_{c(1)}} \sigma_c \epsilon_c d\epsilon_c ; \quad (7)$$

$$M_s = A_{s1} E_s \frac{\epsilon_{cf(1)}}{z(1)} (h - z(1) - a_s)^2 + A_{fi} E_{fi} \frac{\epsilon_{cf(1)}}{z(1)} (h - z_1 - a_{fi})^2 \quad (8)$$

**Conclusions.** During the experiment to increase the bearing capacity of the test beams, it is possible to argue about the effectiveness of this simultaneous enhancement of compressed and stretched zones.

The analysis of methods of strengthening reinforced concrete structures showed, that strengthen structures that work for bending can be both a way of increasing the cross-section, and a way to change the calculation scheme of the work of structure. To date, the effect of low-cycle loads of high levels on the work of strengthened bending reinforced concrete elements is not fully investigated. Research in this area is relevant and necessary for modern construction. The use of modern carbon-plastic materials and steel-fiber reinforced concrete is an effective way to strengthen bending reinforced concrete elements. The development of such a method to enhance and improve the algorithm of calculation is very relevant, whereas comparing theoretical research with the results of the experiment will prove the reliability of the theoretical conclusions and prerequisites that were laid down in their basis, as well as talk about their application in practice.

1. Valovoy M.O. Influence of repeated loads on strength, deformability and crack strength of reinforced concrete beams on wastes of enriched ferro-concrete ores // Resource-saving materials, constructions, buildings and structures. - Rivne, 2009. - Issue 18. - P. 456-462.

2. Smolyaninov M.Y. Increase of strength and crack strength of reinforced concrete elements reinforced by acrylic polymer solution, under the action of short-term static and repeatedly repeated loads: author's abstract. Dis. Cand. Tech. Sciences: 05.23.01 / M.U. Smolyaninov - Kharkiv: UDASH, 2007. - 23p.

3. Dovbenko V. S. Stress-deformed state of reinforced concrete bending elements reinforced by a polymer composition - author's abstract. Dis. Cand. Tech. Sciences: 05.23.01 / National university of water and environmental engineering. - Rivne, 2015.- 240 p.

4. Kvasha V.G. Calculation of the strength of normal sections of reinforced concrete beams, reinforced by external glued composite reinforcement, on the basis of deformation model / Resource-saving materials, constructions, buildings and structures. - Rivne, 2008. - Issue 16. Part 1. - P. 363-371.

5. Klimpush M.D. Calculation of the strength of normal sections of reinforced concrete beams reinforced by carbon polymers / M.D. Klampush, VG Kvasha // Resource-saving materials, constructions, buildings and structures. - Rivne, 2007. - Issue 15. - P. 270-276.

6. Kisilier M.I. Flexible reinforced concrete elements with glued external steel sheet stretched by fitting under the action of static loads: Author's abstract. dis. Cand. tech. Sciences: 05.23.01 / M.I. Kissiler. - Moscow: NIAB, 1977. - 22c.

7. Boyarchuk B.A. Strength, crack resistance and deformability of reinforced concrete structures with different methods of reinforcement of the stretched zone: dis. Cand. tech Sciences: 05.23.01 / B.A. Boyarchuk - Lutsk, 2003. - 157s.

8. Semeniyuk S. D. the Gain of the compressed zone of reinforced concrete bending elements / Semeniyuk S. D., Voloshenko Y. G. // problems of modern concrete and reinforced concrete: proceedings of the 2 h, h. 1 concrete and reinforced Concrete structures / Minsk, Screenco, 2007. - p. 306-321.

9. Zadorozhnikova IV Strengthening of the compressed zone, as a means of restoring the operational qualities of reinforced concrete bending elements: dis. Cand. tech Sciences: 05.23.01 / IV Zadorozhnikov // Lutsk, 2006. - 140 p.

10. Rimar Y.V. Strength and deformability of reinforced concrete beams reinforced under load by reinforcement fitting: author's abstract. Dis. Cand. Tech. Sciences: 05.23.01 / Y.V. Rimar - Lviv., National. University "Lviv Polytechnic", 2010 - 20s

11. O. Ben Mekki, D. Siegert. 10 m-Span composite ultra-high performance fiber-reinforced concrete-carbon fibres-timber bridge concept: Feasibility validation and vibration monitoring. Mechanics of Advanced Materials and Structures/ June27, 2012.

12. Externally bonded FRP reinforcement for RC structures. Technical report fib, bulletin 14, 2001, – 130 s.

13. External reinforcement of reinforced concrete structures with composite materials. Shilin A.A., Pshenichny V.A., Kartuzov D.V. M. : Stroyizdat. 2007. - 182c.

14. Melnik I.V. Strength and deformability of reinforced concrete beams reinforced by structural composites under different pre-loading conditions / I.V. Melnik, R.Z. Dobrianyky, A.Y. Murin // a collection of sciences works "Building Structures". - Kyiv, 2005. - Issue 56. - P. 121 - 129.

15. Borisyuk O.P. Calculation of bearing capacity of normal cross sections of reinforced concrete bending elements reinforced by external composite reinforcement for the action of low cycle loads / Borisyuk OP, Kononchuk O.P. // Recommendations. - Rivne, 2012. - 38 p.

16. Ziatyuk Y.Y. Results of experimental research of reinforced concrete beams strengthened in compressed and stretched zones / Y.Y. Ziatyuk // Urban Planning and Territorial Planning: Scientific-Technical Collection / Responses Ed. MM Osetrin - K., KNUBA, 2016. - Issue 61 (special) - P. 216 - 222.

17. Ziatyuk Y.Y. The work of reinforced concrete beams strengthened in compressed and stretched zones under the influence of low-cycle loads. / Y.Y. Ziatyuk // Modern technologies and methods of calculations in construction. - Lutsk: LNTU, 2016. - Issue 5. - P. 215 -223.